

IMPORTANT SAFETY INSTRUCTIONS / SAVE THESE INSTRUCTIONS

WARNING PERTAINING TO A RISK OF FIRE OR INJURY TO PERSONS
WARNING – To reduce the risk of FIRE, OR INJURY TO PERSONS:

1. TURN POWER OFF OR UNPLUG AND ALLOW FIXTURE TO COOL BEFORE ANY MAINTENANCE. LIGHTED LAMP IS HOT!
2. LAMP GETS HOT QUICKLY! CONTACT ONLY SWITCH/PLUG WHEN TURNING ON.
3. DO NOT TOUCH HOT LENS, GUARD, OR ENCLOSURE.
4. KEEP LAMP AWAY FROM MATERIALS THAT MAY BURN.
5. DO NOT TOUCH THE LAMP AT ANY TIME. USE A SOFT CLOTH. OIL FROM SKIN MAY DAMAGE LAMP.
6. DO NOT OPERATE THE LUMINAIRE FITTING THAT HAS A MISSING OR DAMAGED REFLECTOR.

PLEASE READ THESE INSTRUCTIONS CAREFULLY BEFORE YOU BEGIN INSTALLATION. FOR WIRE CONNECTION REFER TO MANUFACTURER'S TRANSFORMER INSTALLATION INSTRUCTIONS.

Set-up and Technical Information

1. StoneAge™ Lighting's low voltage system operates at 12 volts rather than 120 volts. This low voltage virtually eliminates any risk of shock during or after installation.

2. Low voltage is normally not subject to the complex electrical wiring regulations associated with 120 volts system.

3. All fixtures must be installed in accordance with all local codes and ordinances.

PLEASE READ INSTRUCTIONS SUPPLIED WITH THE TRANSFORMER FOR CORRECT CONNECTIONS AND START-UP.

Selecting a Transformer

1. When selecting a transformer for your lighting system "refer to chart below", properly calculate the right size and always allow for any future expansion so your transformer can handle this.

Number of Lights	Bulb Wattage	Transformer Wattage
4	50	200
6	35	300
10	20	200

2. Please refer to your transformer's instructions for mounting. If your transformer did not come with mounting instructions, we recommend mounting the transformer a minimum of 12" above ground and always plug into a GFCI type receptacle.

3. Please follow manufacturer's specification on proper balance and load.

Layout

FOLLOW EXACT WIRING INSTRUCTIONS DESCRIBED AND INSTALL IN ACCORDANCE WITH ALL LOCAL CODES AND ORDINANCES.

1. Place your lights in areas you desire where you will achieve your best results. These lights are not for use in decorative fountains or ponds. And, therefore, are not to be installed within 10 feet (3.05m) of a pool, spa or fountain or pond.

2. Lay the main cable on the ground starting at the transformer and run the cable in a continuous line to the lights in order to determine your wire requirements. Refer to Diagram "B". Do not bury cable until system is running and you are satisfied. The main secondary wire is intended for shallow burial less than 6 inches (152mm) unless using wire suitable for direct burial. Low voltage cable can be purchased from your local electrical wholesaler. The secondary wiring is to be routed in close proximity to the luminaire housing or deck.

3. Each light can now be hooked up by attaching the main cable (keep in mind you may want to move the light, therefore, don't cut the wire supplied with fixture) to each light fixture by attaching the quick connectors (if supplied) or connect using electrically approved connectors. Refer to Diagram "B". Connection to the main secondary cable must be made within 3 inches (76mm) of the luminaire.

4. Refer to "Voltage Drop" for the correct number of lights on each main cable. (There may be more than one main cable coming from your transformer.)

5. After all fixtures are connected, hook main cable(s) to your transformer and test system before burying main cable(s). Test system and make sure all lights are working. If some lights are out, check your connections at the fixture.

6. Bury your cable according to local codes and ordinances.

Installing Stabilizing Base for Bollard Lights

1. When installing bollard type lights you must install a stabilizing base to prevent the bollard from toppling over. The pipe and the base plate must be made of a minimum 1/4" steel or a product of equivalent strength. Refer to "Diagram A".

2. To mount your bollard light, first secure the stabilizing base to the ground.

- If your stabilizing base came with a ground spike, insert the spike all the way into the ground until the base plate is level with the ground.
- If your stabilizing base did not come with a ground spike, you must secure it to the ground by fastening it to a concrete pad, or concrete filled tube, by drilling into the base and anchoring it to the concrete with the appropriate bolts. Anchoring bolts can be purchased from your local hardware store.
- Once the stabilizing base is secure, lift bollard light over the metal pipe and slide it down into place over the pipe. Refer to "Diagram A".

Care & Maintenance

Once installed, your StoneAge™ Lights will be exposed to the elements such as rain, snow, sun, dust and dirt. Although designed for such elements, we suggest the following to ensure years of problem free lighting:

1. Remove lamps from their fixture once a year and spray socket and contact points with a silicone based spray. This will help prevent moisture from tarnishing the metallic components of the lamps and sockets.

2. Clean or wipe glass on the fixture periodically of dust and debris, this is particularly true of the spot lights.

3. Grease (silicone base) the fixture approximately once per year where the cover meets the base of the fixture. This will prevent it from corrosion allowing easy access when replacing bulbs.

4. When replacing bulbs, ensure that the prongs line up perfectly with the socket and press firmly into place using both thumbs for equal pressure.

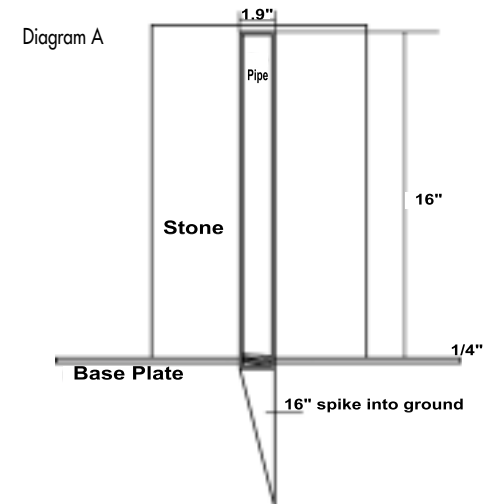

Bulb



Light Fixture

Voltage Drop - READ THIS SECTION CAREFULLY

$$\text{Voltage drop} = \frac{\text{Total lamp wattage} * \text{Cable length}}{\text{Cable Constant}}$$

*See Chart #1 for standard constant.

CHART #1	Wire Size	Cable Constant
	# 10 Wire	11920
	# 12 Wire	7500
	# 14 Wire	3500
	# 16 Wire	2200
	# 18 Wire	1380

Example #1: If running 4 lights on 1 line (12 Gauge) at 50 watts each to a distance of 60ft., you would have a voltage drop of 1.6 volts.

$$(4 \times 50 \text{ watts}) = 200 \text{ watts} \times 60\text{ft} = \frac{12000}{7500} = 1.6 \text{ volts}$$

Please keep in mind heavier cable or lower wattage bulbs can also be used to reduce voltage drop.

Example #2: If running 6 lights on 1 line (12 Gauge) at 20 watts each to a distance of 60ft., you would have a voltage drop of .96 volts.

$$(6 \times 20 \text{ watts}) = 120 \text{ watts} \times 60\text{ft} = \frac{7200}{7500} = .96 \text{ volts}$$

When setting up your system, the voltage drop should not exceed 2 volts. You can reduce voltage drop by using 20w or 35w bulbs instead of 50w, or by using #10 gauge wire for long light runs.

DIAGRAM "B" - Wire Layout

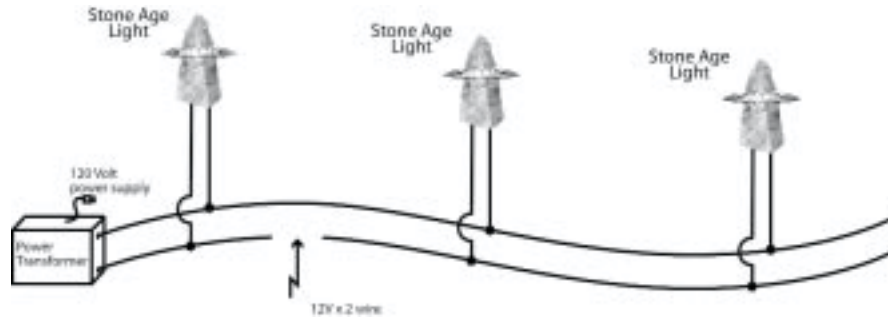

WARRANTY

If within the warranty period specified, this product fails due to a defect in material or craftsmanship, StoneAge™ Lighting Creations Limited will repair or replace it free of charge. This warranty is valid for the original household purchaser only. The warranty does not apply to: (a) damage to units caused by accident, dropping or mishandling, acts of god or any miss use; (b) units which have been taken apart or modified by an unauthorized dealer; (c) units not used in accordance with instructions; (d) lamp bulbs; (e) the finish to any portion of the products, such as surfaces and/or weathering, as this is considered normal wear and tear; (f) damage due to shipping, initial installation cost, removal cost or reinstallation costs.

This warranty gives you specific legal rights and you may also have other legal rights which vary from state to state. Warranty service is available by mailing prepaid postage to: StoneAge™ Lighting Creations Limited, 475 Hwy 5 West, Dundas, Ontario, Canada, L9H 5E2..

Please be sure to securely wrap your product to avoid damage during shipping.

Installation Instructions



StoneAge™ Lighting Creations

Phone Toll Free:
USA 1-888-464-1226
Canada 1-877-277-5177
Email: info@stoneagelight.com
Web Site: www.stoneagelight.com